

INSUL-PIPE SYSTEMS

*PVC CORE * PVC CLAD * SERVICE TEMP: +35 TO +100 F*

PIPING SYSTEM:	Underground pre-insulated chilled water supply and return piping system.
CARRIER PIPE:	POLYVINYLCHLORIDE (PVC) Schedule 40/80, bell and spigot, solvent weld (glue type) joints.
OUTER JACKET:	Polyvinylchloride (PVC) white, low pressure rated, seamless, ASTM D-1784, Class 1, Type 1. Able to withstand H-20 Highway loading. Thickness as shown below.
INSULATION:	Polyurethane, 2.5 PCF density, 90 to 95% closed cell, poured in place, "K" = .14 per inch @ 75 degrees F. Thickness as shown below.
END SEALS:	Factory applied, waterproof mastic covering the urethane insulation at the end of each joint of pipe and bonded to the carrier pipe and the outer jacket.
JOINT COVERS:	Coupling joints on straight pipe are sealed with polyethylene tape at the jacket-to-jacket connection.
FITTINGS:	Fittings are solvent weld type, Schedule 40 PVC, un-insulated and must be provided with concrete thrust blocks at all changes of direction.

Nominal Pipe Size	Insulation Thickness Inches	Jacket O.D. Inches	Jacket Thickness Inches	Insulation "R" Value	Heat Transfer BTU/LF/FDT
1½	1.23	4.50	0.060	8.78	0.0585
2	1.00	4.50	0.060	7.14	0.0872
2	1.82	6.14	0.060	13.71	0.0405
2½	1.55	6.14	0.060	11.07	0.0535
3	1.25	6.14	0.060	8.55	0.0813
4	1.75	8.16	0.080	12.50	0.0741
6	1.68	10.20	0.100	12.00	0.1556
8	1.69	12.24	0.120	12.07	0.1870
10	1.65	14.32	0.140	11.78	0.2388
12	1.47	16.00	0.160	10.50	0.3179

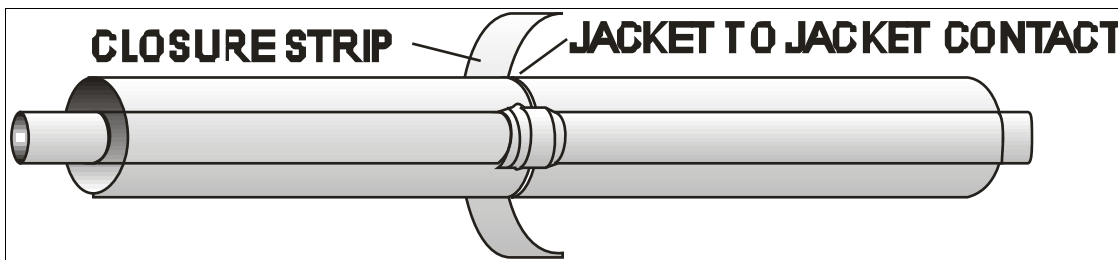

INSUL-PIPE SYSTEMS

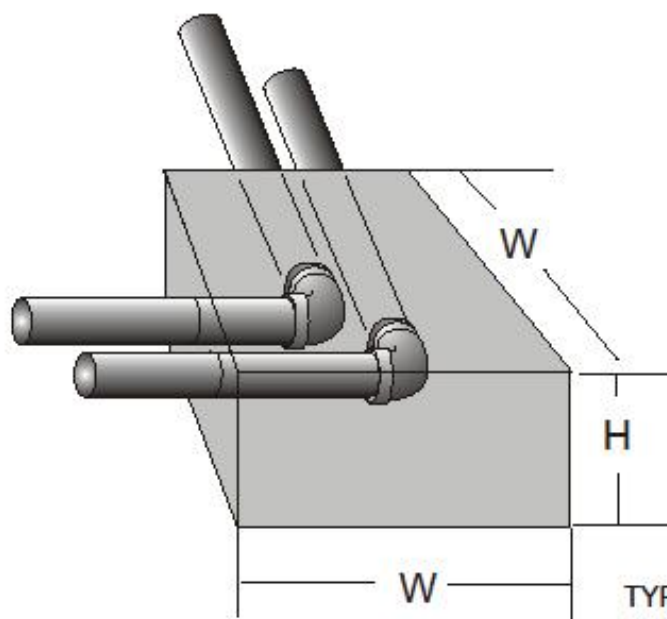

**TYPICAL 90 FITTING
THRUST BLOCK**

SQUARE FEET ON FACE OF THRUST BLOCK "F" TO BE PLACED AGAINST NATIVE SOIL
CALCULATED AS $F \text{ sqft} = H \text{ ft} \times W \text{ ft}$. DETERMINE TOTAL F IF MULTIPLE PIPE SYSTEM USING:

$$\text{SQ. FT REQUIRED EACH PIPE} = \frac{\text{PI} \times (\frac{1}{2} \text{ ID CORE})^2 \times \text{test PSI} \times \text{SAFETY FACTOR}}{\text{HORIZONTAL BEARING CAPACITY OF SOIL (lb/sqft)}}$$

Example: A 10" PVC LINE tested at 150 PSI develops about 12,000 lbs of force at each 90 fitting turn. Using a safety factor of 1.5 we should allow for 18,000 lbs. of force. With 2 lines the force developed would be 36,000 lb. If your soils were disturbed fill with an expected bearing capacity of 750 lb./square foot, the concrete block needs a face against the native soil of 36000/750 or about 48 square feet. IE $H \times W = 48 \text{ sq. ft.}$
This represents a rather large thrust block to prevent blow out of the gasketed system, assuming a conservative low horizontal bearing capacity for the site with disturbed fill characteristics in the top 10' of a construction site and no contribution of jacket friction provided by compacted soil along the pipe run. Other considerations: minimum depth below final elevation, minimum 12" cover of concrete over pipe, "face" required both sides of block to resist force of pipe each direction.

THRUST BLOCK CONSTRUCTION AT 90 GASKET SYSTEM FITTING
THRUST BLOCK SHALL BE INSTALLED AT ALL TURNS. THRUST BLOCKS SHALL BE CONCRETE HAVING A COMPRESSIVE STRENGTH OF NO LESS THAN 2000 PSI AFTER 28 DAYS. THRUST BLOCKS SHALL BE PLACED BETWEEN SOLID GROUND AND THE FITTING TO BE ANCHORED. THE BASE AND THRUST BEARING SIDES OF THE THRUST BLOCKS SHALL BE POURED DIRECTLY AGAINST UNDISTURBED EARTH. THE SIDES OF THE BLOCK NOT SUBJECT TO THRUST MAY BE POURED AGAINST FORMS.

THRUST BLOCK DETAIL AND SIZING

